

Automatic Steel Strapping Systems

Models
M200,
M220

 SIGNODE

Two Signode® power strapping machines —Models M200 and M220—are ideal for automatic packaging of high density loads where the strength of steel strapping is necessary.

Consider the Advantages

A step up from strapping your packages manually, our M200 and M220 power strapping machines help you increase productivity by adding just the amount of automation you need to keep pace with your production schedules.

And you'll build more secure, manageable loads because the adjustable tension capability of both machines allows you to pull the exact amount of tension needed.

Versatility

Both power strapping machines are available in 56 standard chute sizes for versatility in strapping packages from 12" (304.8 mm) high and 12" (304.8 mm) wide to 48" (1.2 m) high and 54" (1.4 m) wide, in 6" (152.4 mm) increments.

Ease of Maintenance, Repair

Models M200 and M220 have modular components that make for easy maintenance, trouble-shooting and repair. Other benefits include:

- Nickel plated strapping chute to resist corrosion.
- Stainless steel gates for durability, rust prevention.
- Heavy gauge bar for chute alignment support.

Ease of Operation

An operator simply positions a package in the chute and activates a footswitch, to automatically apply, tension, seal and cut the steel strapping. Material waste is eliminated because no extra strap has to be cut off and discarded.

Use Nestack® Seals

Magazines of both power strapping machines accept Signode Nestack seals, held together in a clip by interlocking nibs on the seals rather than by a separate wire. This permits partial seal loading when desired.

For medium-duty, high volume strapping applications

The M200 incorporates the proven M20 steel strapping head into a new machine, with versatility and space saving features that make it ideal for a fully automated operation. Tension can be set from 50-1200 lbs. (233-5430 N) for packaging loads that require the strength of steel strapping.

The M200 uses the following types and sizes of Signode steel strapping:

Strapping Type	Strapping Width		Thickness or Gauge	
	inches	mm	inches	mm
Apex™	3/8	9.5	.015-.020	.381-.508
Apex or Magnus®	1/2	12.7	.015-.023	.381-.584
	5/8	15.9	.015-.023	.381-.584
	3/4	19.0	.015-.035	.381-.889



SIGNODE MODEL

M200

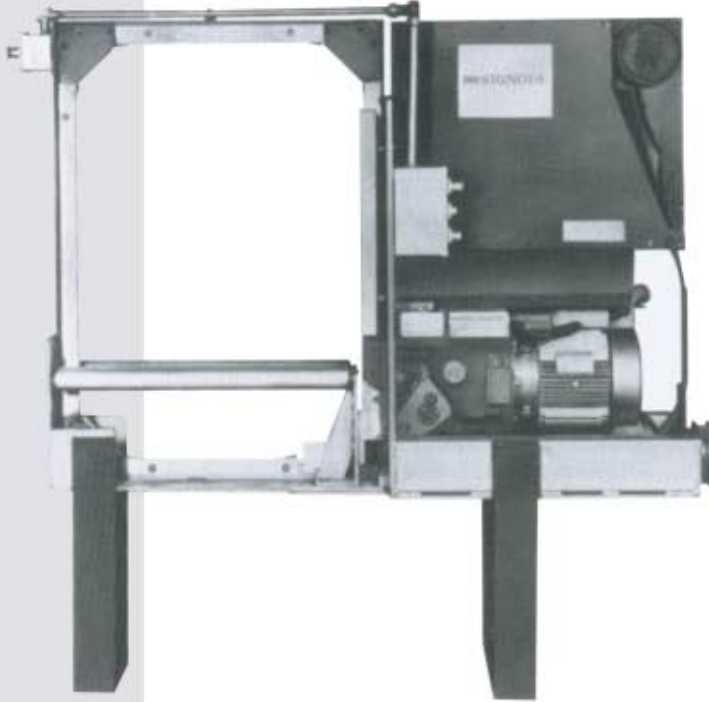

For heavy-duty, high volume strapping applications

A heavy, durable power strapping machine, the Model M220 applies the highest amount of tension, from 50-1600 lbs. (223-7117 N), or 100 to 2200 lbs. (445-9790 N) for the high tension version.* It uses 5/8" (15.9 mm) or 3/4" (19.0 mm) Magnus® or Apex™ in thicknesses from .015-.023" (5/8") or .015-.035" (3/4"). The M220 is ideal for packaging heavy-duty lumber, metal structures, castings, and other dense, heavy loads.
 *Available only in 3/4".

For Sales & Service:
 R.V. Evans Company
 800-252-5894
 www.rvevans.com

Package specifications:

Model	M200-CC M220	M200-DD M220	M200-EE M220	M200-FF M220	M200-GG M220	M200-KK M220	M200-HH M220	M200-JH M220
Max. pkg. width*	12" 305 mm	18" 457 mm	24" 610 mm	30" 762 mm	36" 914 mm	42" 1067 mm	48" 1219 mm	54" 1372 mm
Max. pkg. height*	12" 305 mm	18" 457 mm	24" 610 mm	30" 762 mm	36" 914 mm	42" 1067 mm	48" 1219 mm	48" 1219 mm

*Or any combination of these dimensions

	Distance between conveyor & seal centerline		Minimum package heights for rigid loads	
M200	1-1/2"	(38.1 mm)	4"	(101.6 mm)
M220	4-1/2"	(114.2 mm)	7"	(177.8 mm)
	7-1/2"	(190.5 mm)	10"	(254.0 mm)

Note: For compressible unit loads, add 1" (25.4 mm) to minimum package heights.

Conveyor height:

Same for M200 and M220
 9" (228.6 mm) with 7-1/2" (190.5 mm) seal centerline, 32" (812.8 mm) max.
 12" (304.8 mm) with 4-1/2" (114.3 mm) seal centerline, 35" (889.0 mm) max.
 15" (381.0 mm) with 1-1/2" (38.1 mm) seal centerline, 38" (965.2 mm) max.
 Note: Other heights available in 1" (25.4 mm) increments.

Specifications:

Model	M200	M220**
Strap feed, Speed take-up	36" (914 mm)/sec. 36" (914 mm)/sec.	31" (787 mm)/sec. 31" (787 mm)/sec.
Strapping head motor	3 H.P. (2.23 kW)	3 H.P. (2.23 kW)
Electrical requirements	230/460 V 3 Phase, 60 Hz	230/460 V 3 Phase, 60 Hz
Seal: Type: (Seal located at side of package)	Double Notch 38 MNA 300 Cap. 12 MNA 250 Cap. Single Notch 58 MNA 250 Cap. 34 MNK 250 Cap.	Double Notch 58 MB 300 Cap. 34 MB 250 Cap.
Options	Interlock *Retraction	Interlock *Retraction

* Strapping head returns to its original starting position after completing each strapping cycle. Air required with Retraction Option.
 ** The 3/4" (19.0 mm) high-tension model has 23" (584 mm) per sec. strap feed and take-up rate.



Strap dispenser:

The Model DF1-12 should be used with these power strapping machines.